



Specification

Finish/Colour:	Black
Main Construction Material:	Brass
No of Controls:	2
Shower Type:	Recessed Shower
Shower Head Type:	Fixed Head & Multi-Function Handset
Shower Kit:	Adjustable Riser with Fixed Head
Valve/Cartridge Type:	40mm Cartridge
Maximum Hot Water Supply Temperature °C:	65
Plumbing System Suitability:	Suitable for all plumbing systems
Minimum Dynamic Pressure (bar):	0.2
Maximum Dynamic Pressure (bar):	5
Maximum Static Pressure (bar):	10
Connection Inlet:	15mm Compression
Connection Outlet:	G1/2"
Isolation Valve Included:	No
Check Valve Included:	Yes

Features:

- This shower pack contains a Salcombe shower valve with a 200mm round shower head and wall arm; an adjustable riser shower kit with a multi-function handset, hose and wall outlet
- Two outlets recessed valve option with dual controls for separate flow and temperature adjustability
- Thermostatic temperature control and automatic stop prevent surges of hot or cold water
- Smallest recessed valve on the market which has been designed to fit into a 35mm deep cavity space
- 15mm inlet connection

Product Certifications:



Additional Information:

Dimensions (measurements in mm)

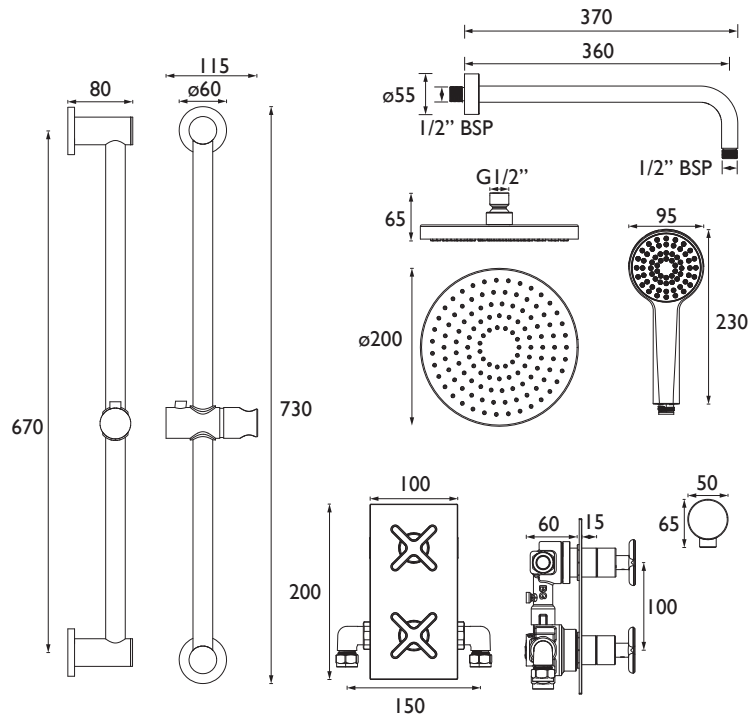

Flow Rates (l/min)

System Pressure (bar)	0.2	0.5	1	2	3	5
Through Handset (mixed)	3.4	5.4	8	11.8	14.7	19.5
Through Fixed Head (mixed)	6.2	9.8	14.3	20.6	25.5	33.1