

HERITAGE

BATHROOMS

Installation Guide



Models Covered:

**Dartmouth 3 Hole Wall Mounted
Basin Mixer**

**TDACC310 / TDACBB310 /
TDACBL310**

Please keep this booklet for future reference.

Installer: When you have read these instructions,
please ensure you leave them with the user.

INTRODUCTION

Thank you for buying a Heritage Product. When you buy a Heritage product, you can be confident that it not only features a beautiful, distinctive, classic design, but that it has also been made to the very highest quality standards.

To ensure that it works to its full potential, it needs to be fitted correctly.

These fitting instructions have been created to give you all of the information you need and, if you need any further help, please do not hesitate to give us a call on: **0330 026 8503**.

CONTENTS

SAFETY NOTES	3
SPECIFICATION	3
PACK CONTENTS	4
TOOLS REQUIRED	4
PRIOR TO INSTALLATION	5-6
INSTALLATION	6-8
TROUBLESHOOTING	8
MAINTENANCE	9-10
CARING FOR YOUR PRODUCT	11
GUARANTEE	11
NEED HELP?	11



SAFETY NOTES

All products manufactured and supplied by Heritage are safe to use provided that they are installed, operated and receive regular maintenance in accordance with these instructions.

This product needs to be installed in accordance with, and meet the requirements of the Water Supply (Water Fittings) Regulations 1999 and current by-laws.

Isolation valves must be fitted to the inlet water supplies to ensure ease of future maintenance.

Before installing this product the water supply must be thoroughly flushed in order to remove any swarf, solder etc. Full access must be made available for future maintenance/ servicing purposes.

If power tools are used do not forget to:

- Wear eye protection
- Unplug equipment after use

This product must not be modified in any way as this will invalidate the guarantee.

If in doubt, contact a registered plumber, your Local Water Authority or the Secretary of the Institute of Plumbing, address as follows:-

The Institute of Plumbing,
64 Station Lane,
Hornchurch,
Essex,
RM12 6NB, Tel: 01708 472791

SPECIFICATION

OPERATING PRESSURE RANGE (BAR): TDAC__310 - Min 0.5 bar, Max 5.0 bar

MAXIMUM STATIC PRESSURE (BAR): 10 bar

INLET WATER TEMPERATURE RANGE: Hot - Max 65°C

INLET CONNECTIONS: 15mm Compression Connections

CAVITY DEPTH: Min - 45mm
Max -60mm



PACK CONTENTS

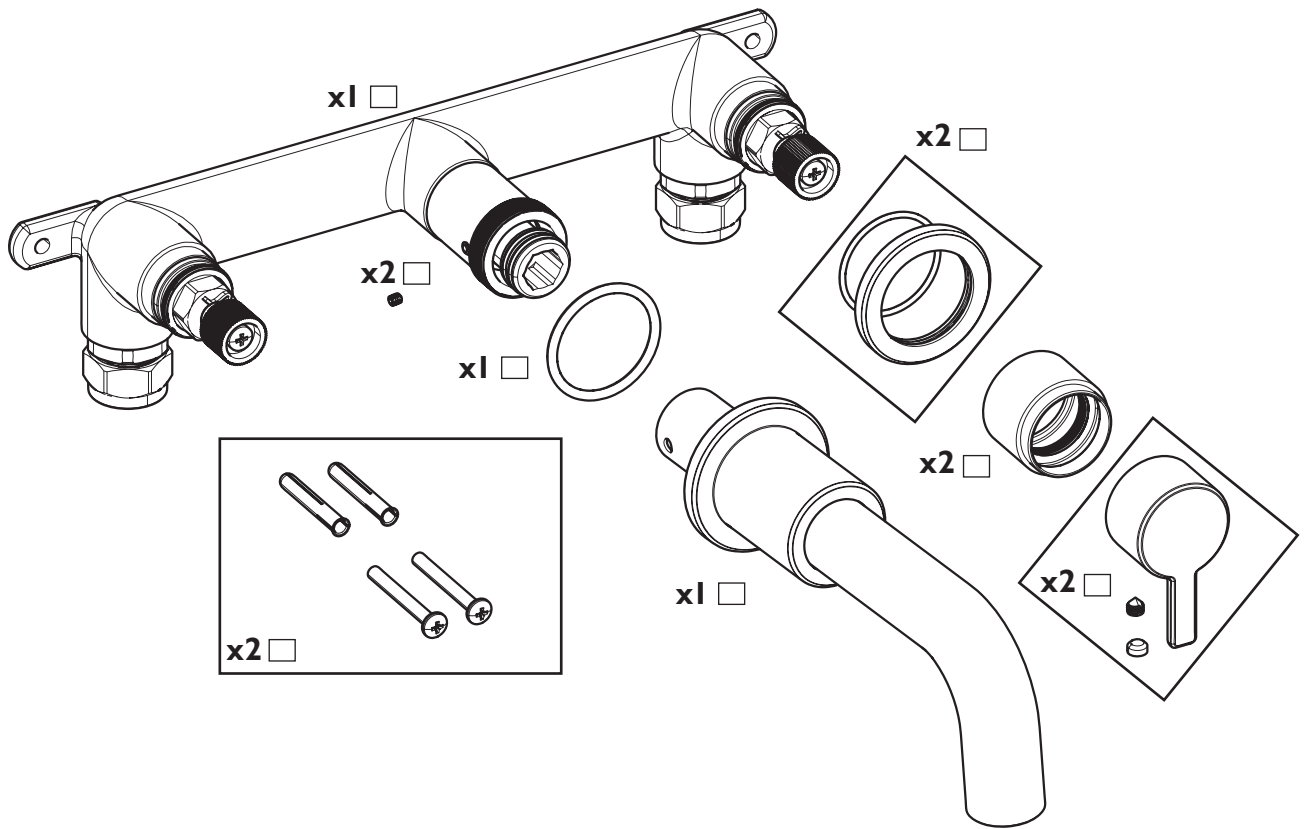

TOOLS REQUIRED

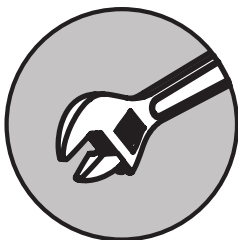

**Adjustable
Spanner**

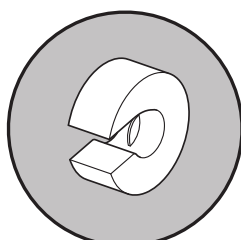

Pipe Cutter

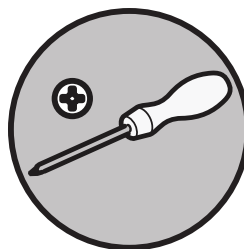

**Cross Head
Screwdriver**

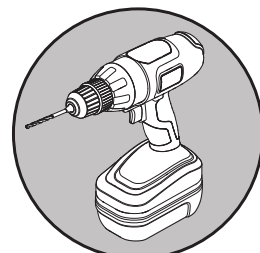

Drill

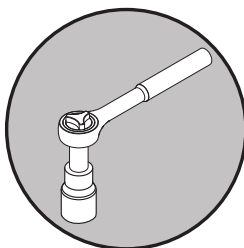

**17mm Socket
Spanner**

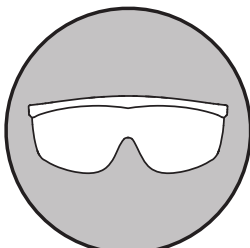

Safety Goggles

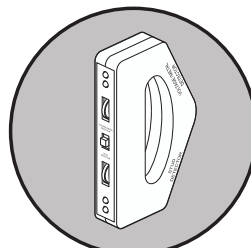

**Electronic
Detector**

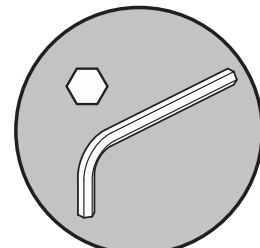

**2.5mm
Hexagonal Key**



PRIOR TO INSTALLATION

Typical Installation

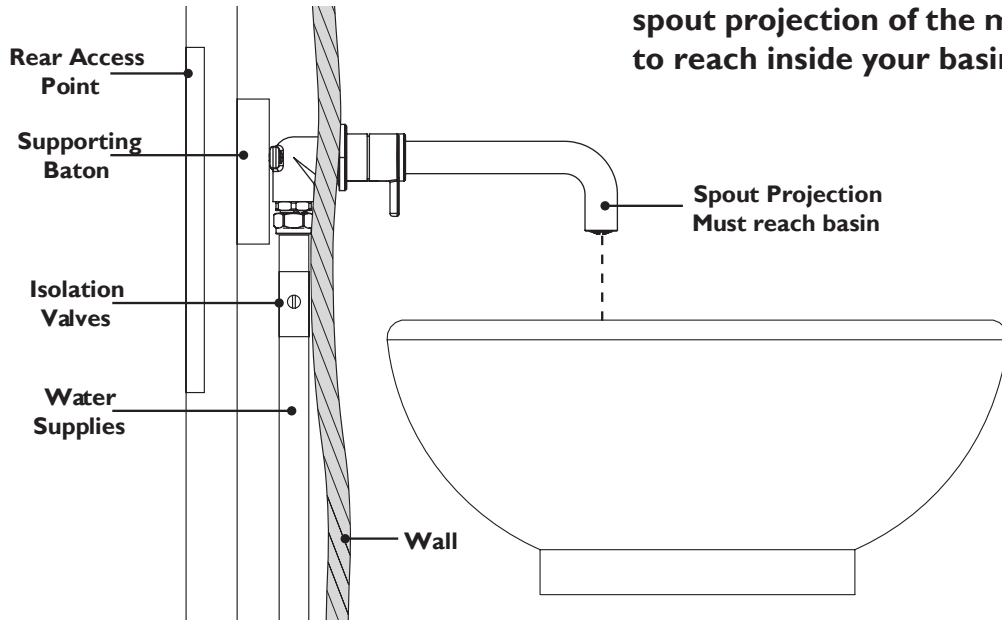

Plan your installation, ensuring that the spout projection of the mixer will be able to reach inside your basin.

Critical Dimensions

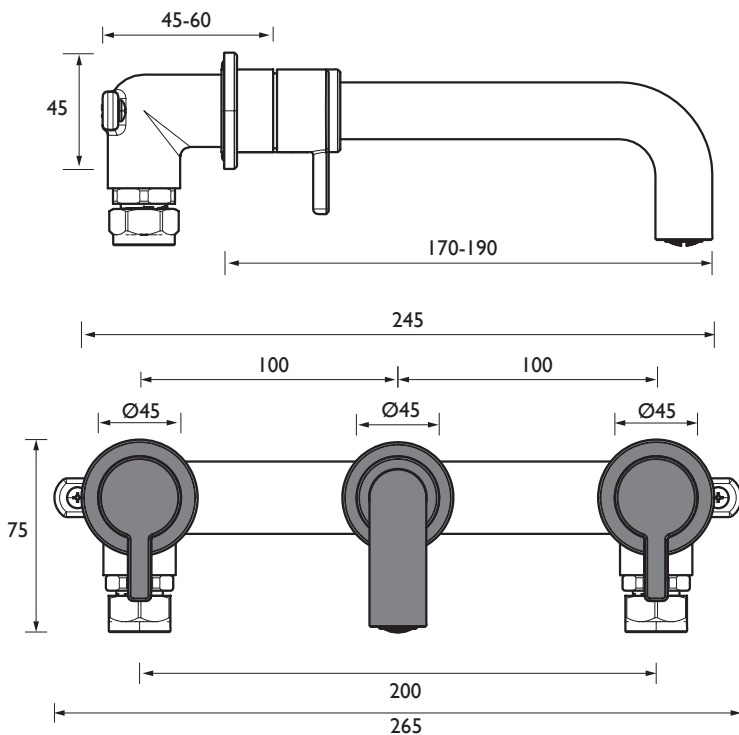

Please ensure that the installation and accommodation is designed with future serviceability of the product in mind. Rear access will also be required in order to access the valve for future maintenance/re-fitting purposes. It is strongly advised to fit isolation valves to the water fixtures in an easy to access location; in case isolation is required at any point during maintenance.

In the event a future claim is made under the product warranty, the design of the installation may affect compensation costs if it has not been considered in the original design. Failure to observe crucial information in these fitting instructions will nullify your guarantee.

This product requires experience within plumbing. No responsibility will be taken for poor workmanship resulting in leaks and injuries.



PRIOR TO INSTALLATION

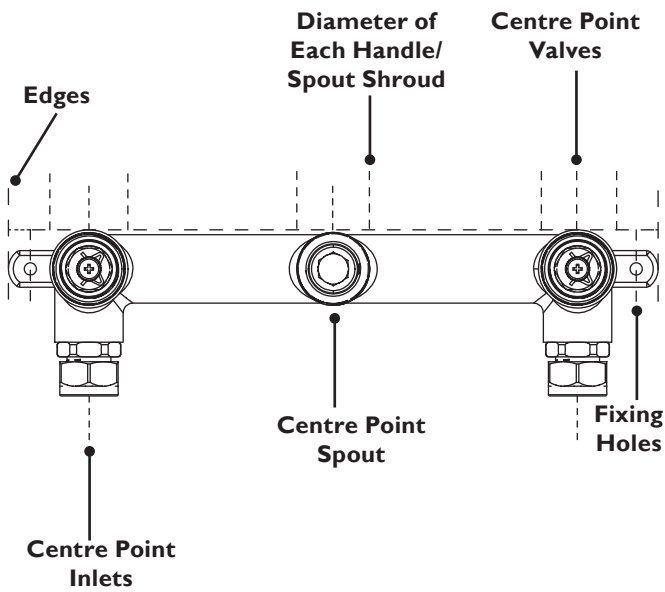

Take note of the following dimensions when fitting, or mark on the fitting location where needed.

The plinths are separated so care will need to be taken when finishing the wall surface to make sure the fixing holes are covered but also allow for the valve to come through.

When creating the wall cavity, make sure to accommodate for the wall finish in your measurements.

INSTALLATION

1

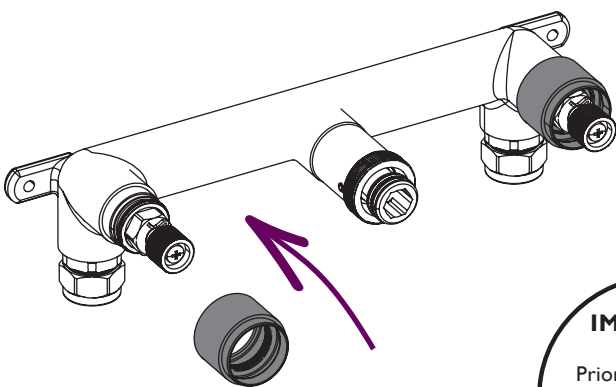

Screw the shrouds on to the valve body.

2

Take the necessary measurements as per pg. 5 and mark the desired location for the valve on the wall.

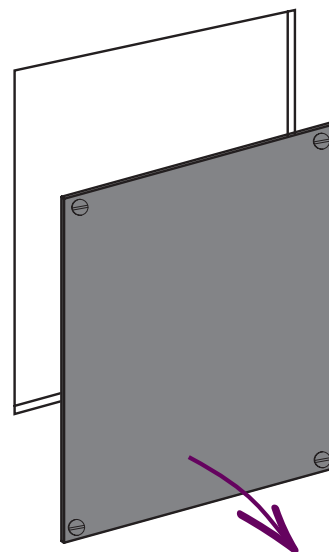

Cut out the space required to fit the valve at the front. Create the rear access point on the other side of the wall for maintenance purposes.

IMPORTANT
Prior to drilling into walls check there are no hidden electrical wires, cables or water supply pipes.



INSTALLATION

3

Rear Access Point

Front Cut-Out

Baton

REMEMBER
Refer to the critical dimensions on pg. 5. Allow for the wall finish when measuring!

Measure the cavity depth and allow for a sufficient amount of the valve to protrude through the wall for fitting. Install suitable batons if necessary to secure the valve.

4

Mark and drill the fixing holes (4mm drill size). Secure the valve body using suitable fixings for

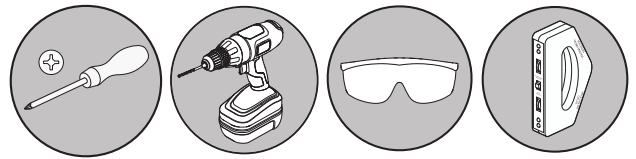

5

Plumb the hot and cold water supplies to the valve body. Fit isolation valves (not supplied) as close as possible to the valve body. Turn on the water supply and check all joints and connections for any leaks.

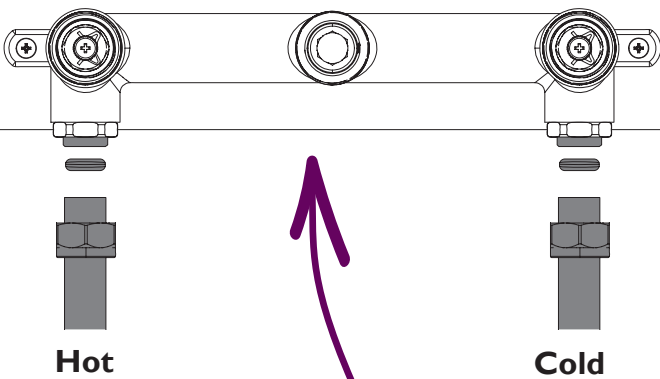

Hot

Cold

6

Finish the wall. Push the spout on to the centre fitting and secure with the grub screws. Screw on the shroud, ensuring the O-Rings are in place.



2.5mm

INSTALLATION

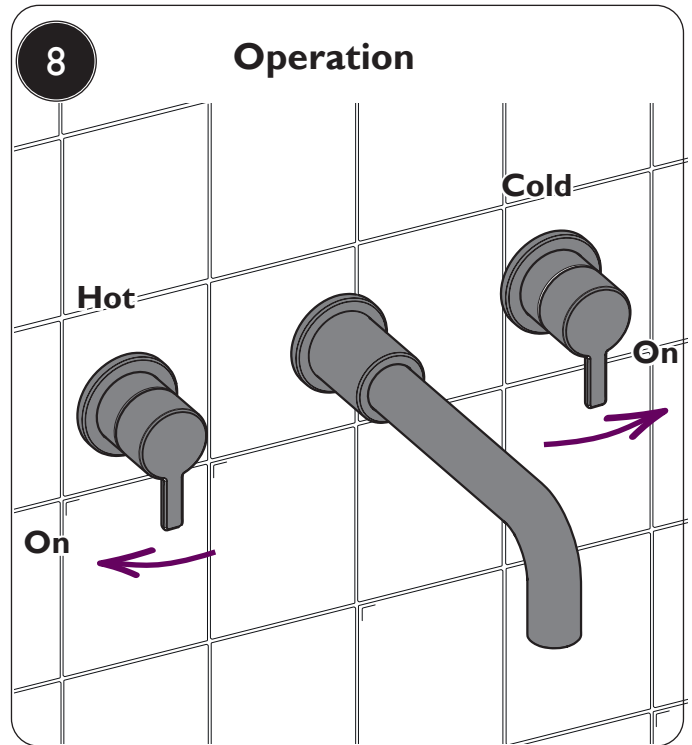
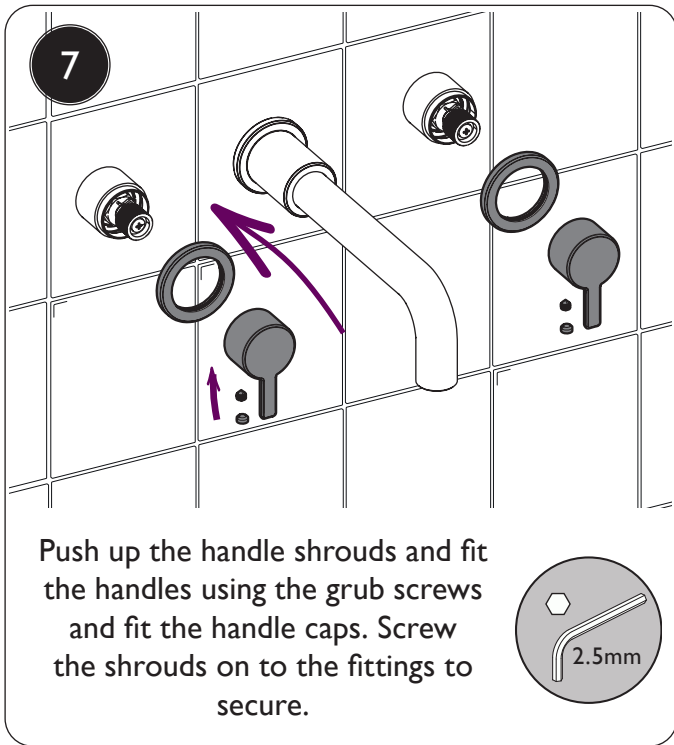

TROUBLESHOOTING

Symptom	Cause	Remedy
No flow or low flow rate	Partially closed isolation valve.	Open isolation valve.
	Instantaneous water heater cycles on and off as flow rate or pressure is too low.	Increase water flow rate or pressure through system.
	Head of water is below the minimum distance required.	Refer to specification for minimum distance required.
	Hot or cold water being drawn off elsewhere causing pressure changes or instantaneous boiler temperature changes.	Do not use other water outlets when using the taps.
	Airlock or partial blockage in the supply pipework.	Flush through pipework to ensure removal of debris and any airlocks.
Water dripping from taps	This is normal for a short time after using the taps.	This is caused by residual water tension, the build up of water in the tap body.
	If water continues to drip, possibly due to the ceramic disc valves	Remove valves and clean, refer to 'Maintenance' section before starting any maintenance.
Taps do not turn on	Closed isolation valve.	Open isolation valve.
	Mains water supply turned off.	Turn on mains water supply.



MAINTENANCE

1 To Replace Valves

Undo the grub screws and caps to remove the handles.

Undo the screws to remove the spline adaptors.

Use a 17mm socket spanner to remove the valves.

IMPORTANT
Isolate the water supply before starting!

2.5mm

3

Visit www.heritagebathrooms.com or scan the QR Code and search for your product code to replace valves if necessary.

4

Reverse the steps to replace the valves and handles.

MAINTENANCE

1 Clean/Replace Outlet

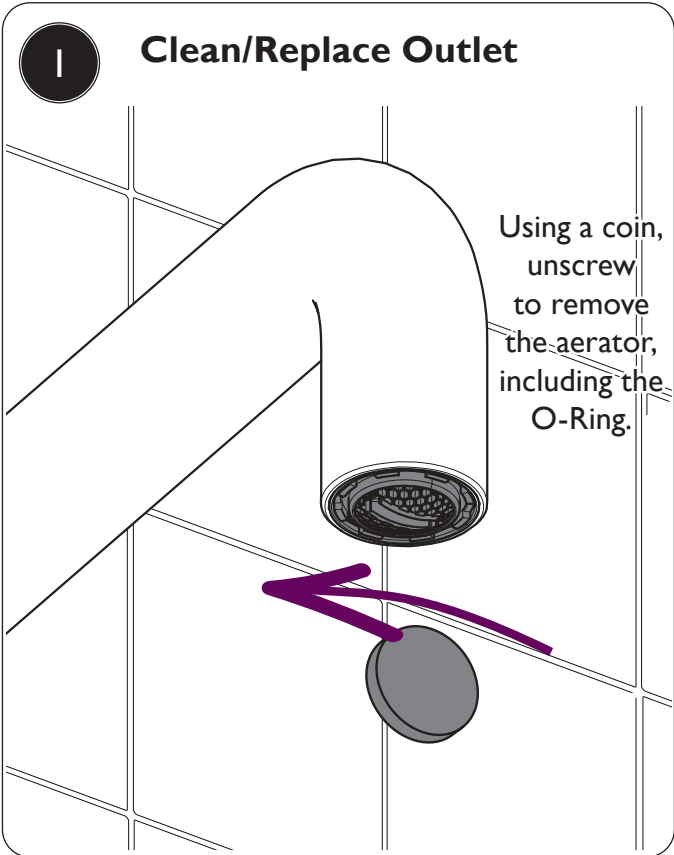

Using a coin, unscrew to remove the aerator, including the O-Ring.

2

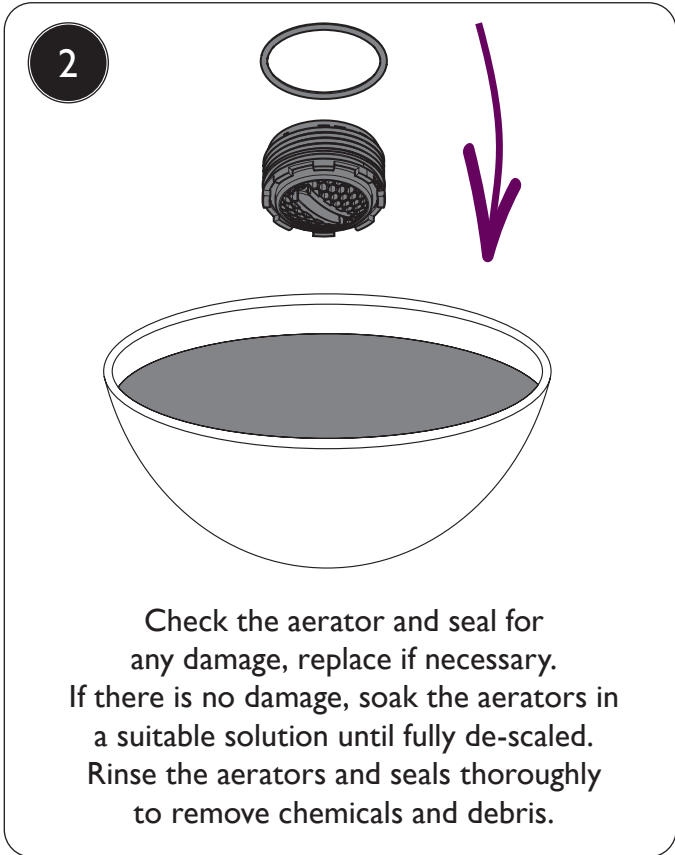

Check the aerator and seal for any damage, replace if necessary. If there is no damage, soak the aerators in a suitable solution until fully de-scaled. Rinse the aerators and seals thoroughly to remove chemicals and debris.

3 Replace the aerator, ensuring the seal is in place.

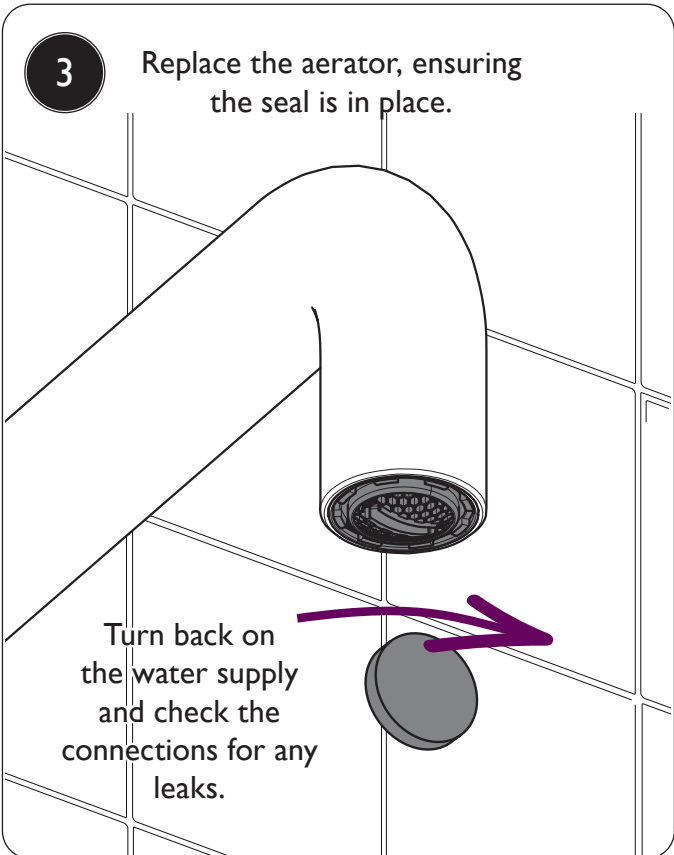

Turn back on the water supply and check the connections for any leaks.

Spare Parts



Please visit www.heritagebathrooms.com or scan the QR Code and search for your product code to replace any available spare parts for your tap.



CARING FOR YOUR PRODUCT

Heritage products are made from premium materials, with hand polished, electroplated, PVD or EPD finishes.

Your taps or shower should be regularly cleaned with warm water, a mild pH-neutral liquid soap, and polished with a soft cloth. Any residues from soap, toothpaste, shampoos and shower gels can cause blemishes if not rinsed off straight after use.

Household bleaches and cleaners contain harsh chemicals and may damage the surface finish. Avoid using abrasive cloths, scouring pads, scrub sponges, steel wool or anything similar.

Some surfaces such as nickel and pewter may be affected by the dye found in some cloths, so it is also important to avoid hanging cloths on spouts.

Your handset comes with rub clean nozzles, simply rub your fingers over the nozzles to clear any any build-up or debris.

GUARANTEE

The confidence we have in the quality of our products and services enables us to offer a free peace-of-mind product guarantee from 2 years up to a lifetime guarantee against any manufacturing faults, with proof of purchase. In addition, our attentive customer service team are available to help solve any problems which may arise quickly and effectively so you can enjoy your bathroom.

To see the specific guarantee for this product, scan the QR Code or visit the following URL:

<https://www.heritagebathrooms.com/service-centre/guarantee>

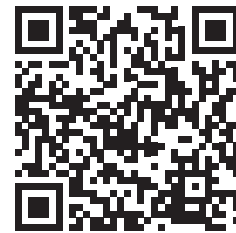

NEED HELP?

In the unlikely event that you encounter a problem with your Heritage product, you must, in the first instance, contact the retailer you purchased it from. They will advise as to whether it is due to a manufacturing fault or an installation fault. If the problem is due to a manufacturing fault, they will contact us to arrange a supply of a replacement product as soon as possible. To speak to a Heritage customer service advisor, please contact our technical helpline on **0330 026 8503**.



HERITAGE[®]

BATHROOMS

We love to see how Heritage products are used so please keep in touch and share pictures of your new bathroom with us.



@heritagebathrooms

If you have any queries, our dedicated customer service teams and products experts are available to help.

Email us enquire@heritagebathrooms.com Call us 0330 026 8503 Website www.heritagebathrooms.com

UK: Heritage Bathrooms, Pooley Hall Drive, Birch Coppice Business Park, Dordon, Tamworth B78 1SG

EU: Masco Europe S.à.r.l., 14 Rue Strachen, 6933 Mensdorf, Luxembourg.