

# MAMC590

## AMBERLEY Furniture Range Amberley Illuminated Circular Mirror (with Hanging Strap) 590mm Chrome



### Features:

- LED lighted mirror with edge-lit diffuser
- IR sensor allowing for contactless control
- On/off dimming capability
- Colour temperature changing with 3 options, 3000k, 4000k and 6500k
- Demister function

### Product Certifications:



This product contains a light source of energy efficiency class F.

### Additional Information:

#### Variant SKUs:

- MAMBL590 - Black

### Specification

Main Construction Material:	Glass
Finish:	Chrome Plated
Weight (kg):	3.5
Assembly Required:	No
Mounting Type:	Wall Mounted
Orientation:	N/A
Height (mm):	950
Width (mm):	590
Total power (w):	24
Input:	AC220 - 240v - 50/60Hz
Connection:	0.9m Power Cable
What's In The Box?	1 x Mirror 1 x Fitting Instructions 1 x Wall Hook and Bracket 3 x Wall Plugs and Screws 2 x Strap Screws

### Dimensions (measurements in mm)

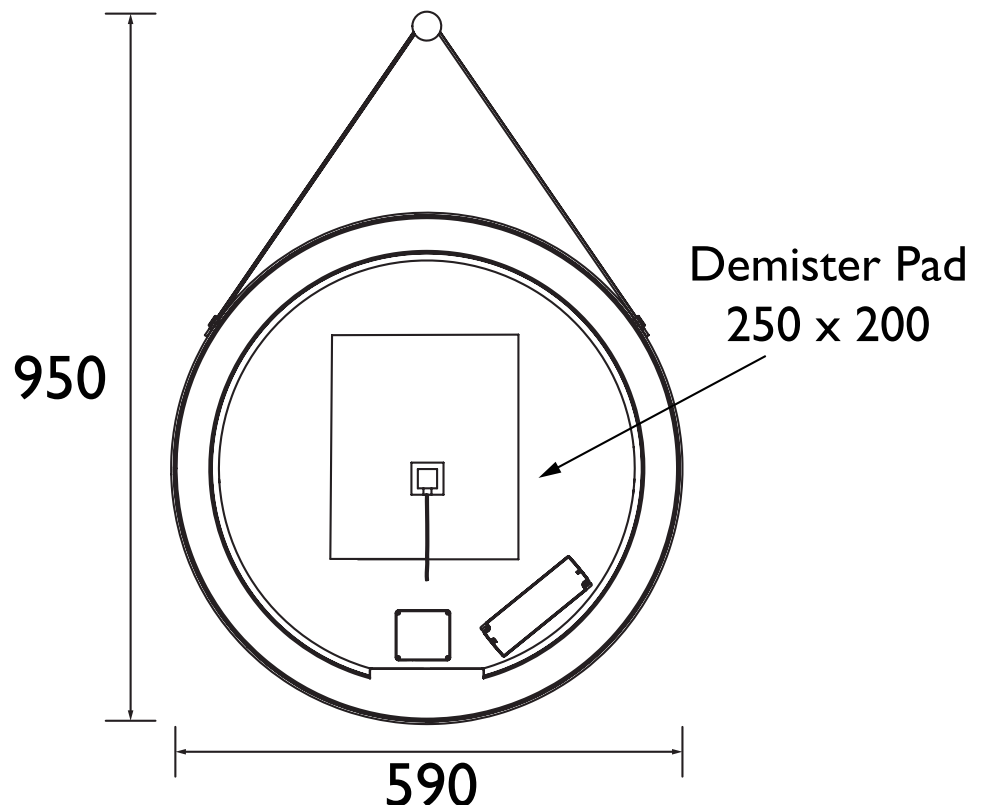

# TECHNICAL DATA SHEET



# HERITAGE<sup>®</sup> BATHROOMS

DI