

## Caversham

### Caversham 300mm Floor Tower Unit Graphite

FFGRAFTU300

#### Product Features

- UK designed. Manufactured to a high quality
- Easy to clean
- Durable to withstand everyday use in a busy household
- Stylish yet functional storage solution
- Adjustable feet for uneven floors
- A choice of over 20 handles to choose from

#### Product Specification

##### Product Construction:

Oak

##### Product Finish:

Graphite

##### Product Weight (Kg):

37.32

##### Packaged Product Weight (Kg):

46.56

#### Dimensions in (mm)

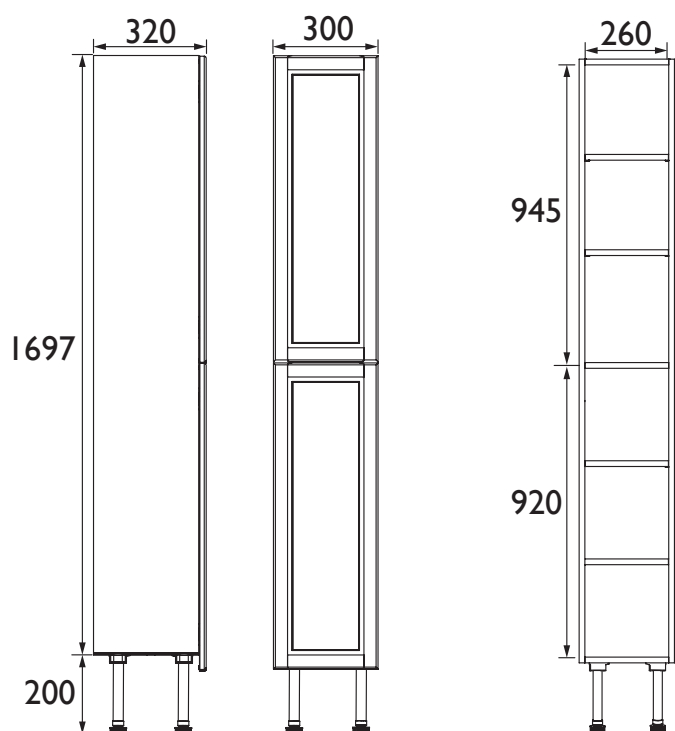

Revision: D1



PRODUCT DATA SHEET

Heritage Bathrooms, Birch Coppice Business Park, Dordon, Tamworth B78 1SG

Tel: 0844 701 8501 | Fax: 0844 701 8502 | Web: [www.heritagebathrooms.com](http://www.heritagebathrooms.com) | Email: [technical@heritagebathrooms.com](mailto:technical@heritagebathrooms.com)

The information contained on this page was correct at date of issue. Fitting dimensions are provided as a guide only. Some variation may occur due to manufacturing tolerances.

Heritage Bathrooms pursues a policy of continuing improvement in design and performance of its products and so reserves the right to change specifications without prior notice

5  
YEAR  
GUARANTEE