

SHDDUAL10

HARTLEBURY Shower Range

Hartlebury Exposed Thermostatic Dual Control Shower Valve with Premium Flexible Riser Kit Vintage Gold



Features:

- 5 Year Guarantee
- Supplied with 2 x 8 l/min. flow regulators
- Adjustable inlet centres mean you can use existing pipework with centres measuring anything between 136mm and 158mm
- Factory fitted regulators means this is a water saving shower
- Matching taps available

Product Certifications:



Specification

Main Construction Material:	Brass
No of Controls:	2
Shower Type:	Exposed Thermostatic Dual Control Shower Valve
Shower Head Type:	Premium Flexible Riser Kit
Valve/Cartridge Type:	Thermostatic
Maximum Hot Water Supply Temperature °C:	65
Maximum Static Pressure: (bar)	10
Plumbing System Suitability:	Suitable for all plumbing conditions
Working Pressure Range: bar	Min: 0.2 Max: 5.0
Connection Inlet:	1/2"
Connection Outlet:	1/2"
Isolation Valve Included:	No
Check Valve Included:	Yes

Dimensions (measurements in mm)

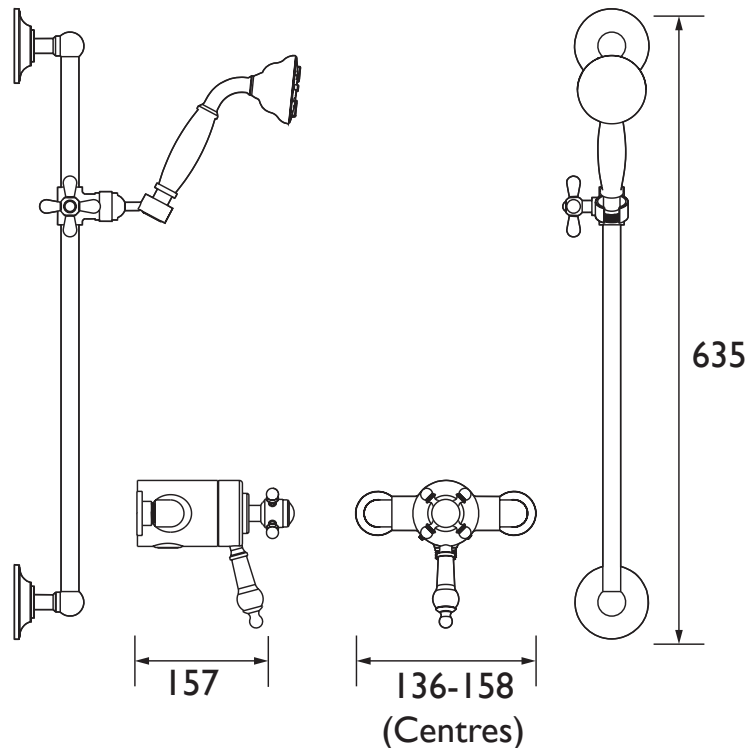

Flow Rates (l/min)

System Pressure (bar)	0.2	0.5	1	2	3	5
With Flow Regulators	6.08	13.5	13.6	14.9	15.1	15.4
Without Flow Regulators	10.5	18.6	27.3	38.61	47.29	61.05

TECHNICAL DATA SHEET



HERITAGE[®]

BATHROOMS

D2