

Features:

- Chrome Plated to BS EN 248
- Supplied with 2 x 8 l/min. flow regulators
- Adjustable inlet centres mean you can use existing pipework with centres measuring anything between 136mm and 158mm.
- Factory fitted regulators means this is a water saving shower
- Matching taps available

Product Certifications:



Specification

Main Construction Material:	Brass
No of Controls:	2
Shower Type:	Exposed Thermostatic Dual Control Shower Valve
Shower Head Type:	Premium Fixed Riser Kit
Valve/Cartridge Type:	Thermostatic
Maximum Hot Water Supply Temperature °C:	65
Maximum Static Pressure: (bar)	10
Plumbing System Suitability:	Suitable for all plumbing conditions
Working Pressure Range:	Min: 0.2 Max: 5.0
Connection Inlet:	1/2"
Connection Outlet:	1/2"
Isolation Valve Included:	No
Check Valve Included:	Yes

Dimensions (measurements in mm)

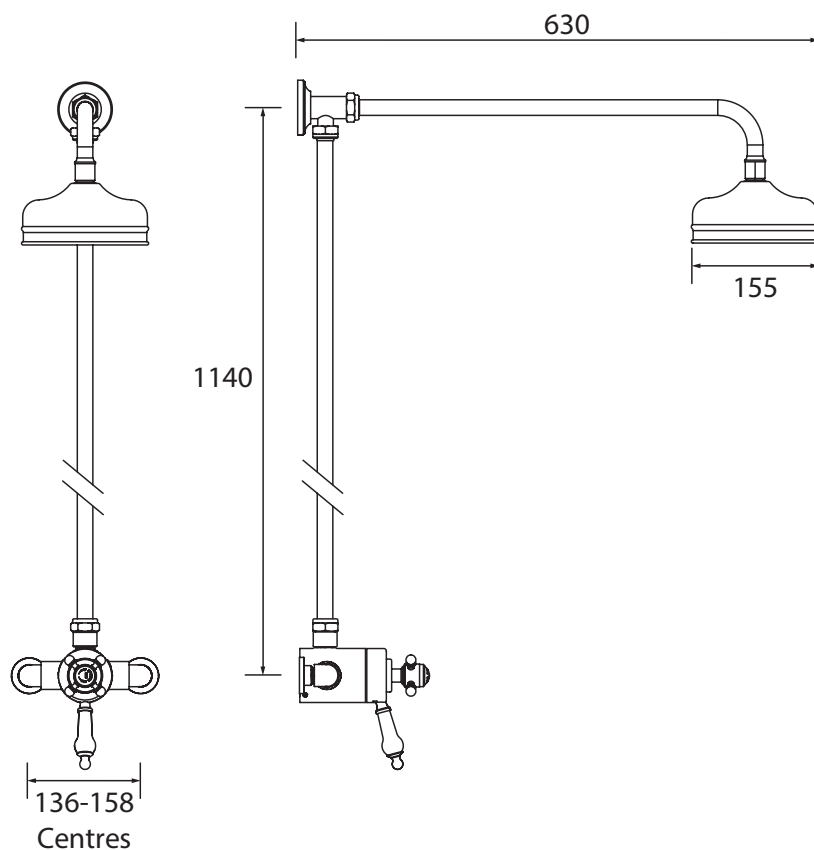

Flow Rates (l/min)

System Pressure (bar)	0.2	0.5	1	2	3	5
With Flow Regulators	-	13	14.1	14.2	15	15.5
Without Flow Regulators	10.6	18.1	26.5	37.5	45.9	59.3