

HERITAGE[®]

BATHROOMS

Installation Instructions and User Guide

Heritage Bath Shrouds

Models covered:

THC30

THA30

THRG30

Please keep this booklet for future reference.

Installer, when you have read these instructions please ensure you leave them with the user.

Introduction

Thank you for choosing Heritage, the UK's market leader for classic bathroom products. To ensure this product works to its full potential, it needs to be fitted correctly. These fitting instructions have been created to give you all of the information you need. If you need any further help, please do not hesitate to give us a call on 0844 701 8503.

Important Safety Information

- Please read these instructions thoroughly and retain for future use.
- All products manufactured and supplied by Heritage are safe provided they are installed, used correctly and receive regular maintenance in accordance with these instructions.
- Remove all packaging and check there are no damaged or missing parts. (See Pack Contents)
- Before starting any installation please consider the following:
 - Before drilling into walls or floors, check that there are no hidden electrical wires, cables or water supply pipes. This can be checked with the aid of an electronic detector.
- If power tools are used do not forget to:
 - Wear eye protection
 - Unplug equipment after use

Pack Contents

1. Tap Mixer Tails	(not supplied)
2. Bath	(not supplied)
3. Tap Washer	(not supplied)
4. Tap Backnut	(not supplied)
5. Flange	x2
6. Floor Plates	x2
7. Connector & Washer	x2
8. Shrouds	x2

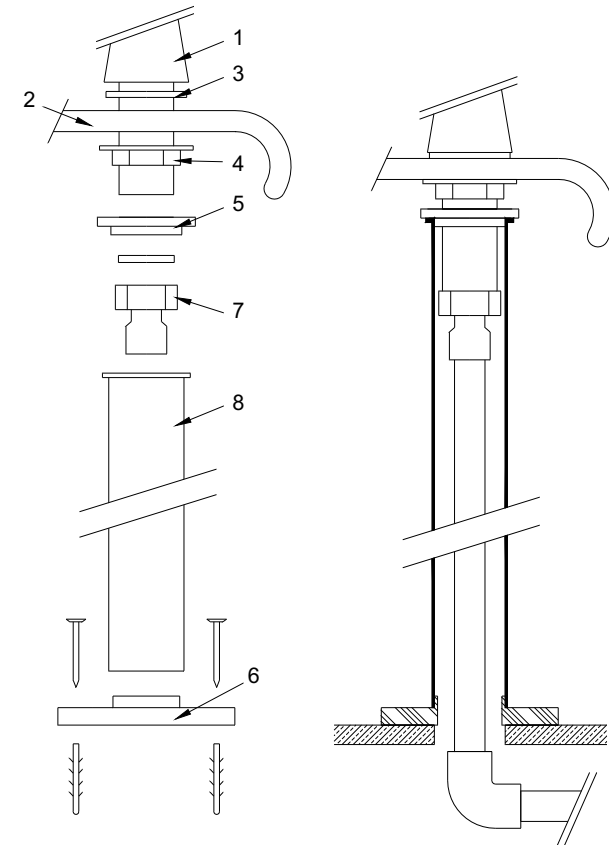

Installation

Bath shrouds are designed to cover pipework which feeds up from under the floor, to taps and mixers that are fitted or supported by a freestanding roll top bath. If it is necessary to shorten the shrouds, it must be done from the floor end.

NOTE: Installation Instructions are only a guide, and the order in which the installation is carried out may be altered to suit on site conditions.

1. Identify all components and check for completeness, particularly before arranging fitting. It may be a good idea to cover the taps to protect them from damage during installation.
2. Loosely arrange the taps or mixer (1) to the bath (2), following their instructions with the washer (3) above the bath and backnut (4) below the bath.
3. Screw the flanges (5) knurled diameter uppermost onto the tails of the taps or mixer.
4. Mark on the floor the position of the pipe inlets
5. Place the floor plates (6) in the desired position, mark out screw holes, drill and using wall plugs if necessary, screw the plates to the floor.
6. The connector (7) supplied can be brazed onto 22mm pipe work (not supplied) to create the vertical feed through the shroud to the taps or mixer. Use a suitable length to allow sufficient movement to aid assembly and to ease further connections below the floor.
7. Slide the shrouds (8) over the vertical pipes ensuring sufficient movement to allow connector (7) to reach the tails. Use the washer to create a seal between the tap tails (1) and the connector (7).
8. Connect the stand pipes to the water supply under the floorboards using elbows (Not Supplied), ensuring the pipes have freedom to move up and down.
9. Secure the taps (1) to the bath (2) using the backnuts (4). Turn the taps on and check all connections for leaks.
10. Screw the shrouds into the floor plates (6) and secure the shrouds in position by screwing the flanges down the tap or mixer tails.



Maintenance & Care

Your product has a high quality finish and should be treated with care to preserve the visible surfaces.

All surface finishes will wear if not cleaned properly.

The only safe way to clean your Heritage Stand Pipes is to wipe with a soft damp cloth. Stains can be removed using washing up liquid.

All bath cleaning powders and liquids will damage the surface of your standpipes even the non-scratch cleaners.



Guarantee

When you buy a Heritage product, you can be confident that it not only features a beautiful design, distinctive, classic design, but that it has also been made to the very highest quality standards.

In the unlikely event that you find a fault with our products, we offer solid guarantees and an attentive aftercare service to ensure that the problem is dealt with quickly and easily.

*Labour is provided by an approved engineer or appointed representative. The guarantee only applies to products with a manufacturing fault. There will be a call out charge for any incidents where no fault has been found with the product, or if the issue is due to poor installation or maintenance.

Guarantee Terms and Conditions

This guarantee is in addition to your statutory and other legal rights and is subject to the following conditions:

- The product was purchased within the United Kingdom or Republic of Ireland.
- The guarantee applies solely to the original purchaser with proof of purchase.
- The installation must allow ready access to all products for the purpose of inspection, maintenance or replacement.

- Repair under this guarantee does not extend the original expiry date. The guarantee on any replacement parts or product ends at the original expiry date.

- Any part found to be defective during the guarantee period will be replaced without charge, providing that the product has been installed in accordance with the instructions given in this guide and used as the manufacturer intended.

The guarantee does not cover:

- Damage or defects caused by:
 - General wear and tear (including special non-chrome finishes; components such as filters, seals, 'O' rings and washers)
 - Incorrect installation
 - Repair using non-Heritage parts
 - Accidental or wilful misuse
 - Corrosion and the use of inappropriate cleaning products
 - System debris including the build up of limescale (which can be controlled through regular servicing and maintenance)
- Compensation for loss of use of the product or consequential loss of any kind.

In the interests of continuous product improvement, Heritage reserves the right to alter product specifications without notice.

The Heritage Product Guarantee does not affect your statutory rights as a consumer.

Guarantee

• Need help?

If this product does not function correctly when first used, contact **Heritage Customer Service on 0844 701 8503** where our expert team of advisors will be able to offer you help and advice.

- Problems during the guarantee period
In the unlikely event that you encounter any problems with the product during the guarantee period, contact **Heritage Customer Service on 0844 701 8503** with your proof of purchase and we will work to resolve the problem quickly.

Heritage Customer Support

Heritage customers also benefit from the support of our comprehensive customer support package which offers:

Technical support hotline

Tel: 0844 701 8503 with access to fully trained advisers who can offer installation advice, talk you through quick maintenance checks, or recommend the best course of action to fix any problems with a product.

Spare parts

We hold thousands of spares and we keep them for discontinued products for over seven years. Spares can easily be ordered online at www.heritagebathrooms.com and are dispatched the same day.

Expert plumbing engineers

If we can't solve the problem over the 'phone or with a spare part, then we'll send out one of our engineers to take a look.

Our engineers provide free support for products that are within guarantee, but are also available to service products that are out of guarantee for a small charge. For details, please call **Heritage Customer Service on 0844 701 8503**.



HERITAGE®

BATHROOMS

Birch Coppice Business Park
Dordon
Tamworth
B78 1SG

Web: www.heritagebathrooms.com
Email: technical@heritagebathrooms.com
Tel: **0844 7018503**

Part Number: Fl: THC/THA30
Issue: D4

