

# HERITAGE

## BATHROOMS

### INSTALLATION GUIDE



#### MODELS COVERED:

THC20  
THA20  
THBN20

Please keep this booklet for future Reference.

Installer: when you have read these instructions please ensure you leave them with the user.

---

# INTRODUCTION



---

Thank you for buying a Heritage Product. When you buy a Heritage product, you can be confident that it not only features a beautiful, distinctive, classic design, but that it has also been made to the very highest quality standards. To ensure that it works to its full potential, it needs to be fitted correctly.

These fitting instructions have been created to give you all of the information you need and, if you need any further help, please do not hesitate to give us a call on 0330 026 8503.

---

# CONTENTS



---

Safety Note .....	3
Installer Guidelines .....	3
Tools Required .....	3
Dimensions .....	4
Pack Contents .....	5
Installation Diagram .....	5
Installation of Standpipes .....	6
Caring for you product .....	7
Guarantee .....	7
Need help? .....	7

---

## SAFETY NOTE

---



Please read these instructions and retain for future use.

All products manufactured and supplied by Heritage are safe, provided they are installed correctly, used correctly, and receive regular maintenance in accordance with these instructions.

If you are in any doubt about your ability to install this product safely you must employ the services of a competent person who has experience of fitting products of this nature.

⚠ Before starting any installation project please consider the following:

- Prior to drilling into walls/floors, check there are no hidden electrical wires or cables or water supply pipes with the aid of an electrical detector.
  - If you use power tools do not forget:
    - Wear eye protection.
    - Unplug equipment after use.
  - This product must not be modified in any way as this will invalidate the guarantee.
- 

## INSTALLER GUIDELINES

---



The installation of these products greatly depends on the floor being level. If this is not the case, it must be corrected before installation.

---

## TOOLS REQUIRED

---

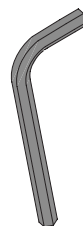
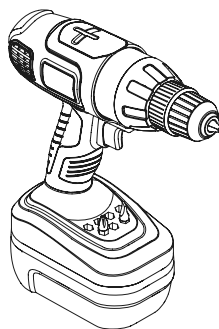

---

## DIMENSIONS

---

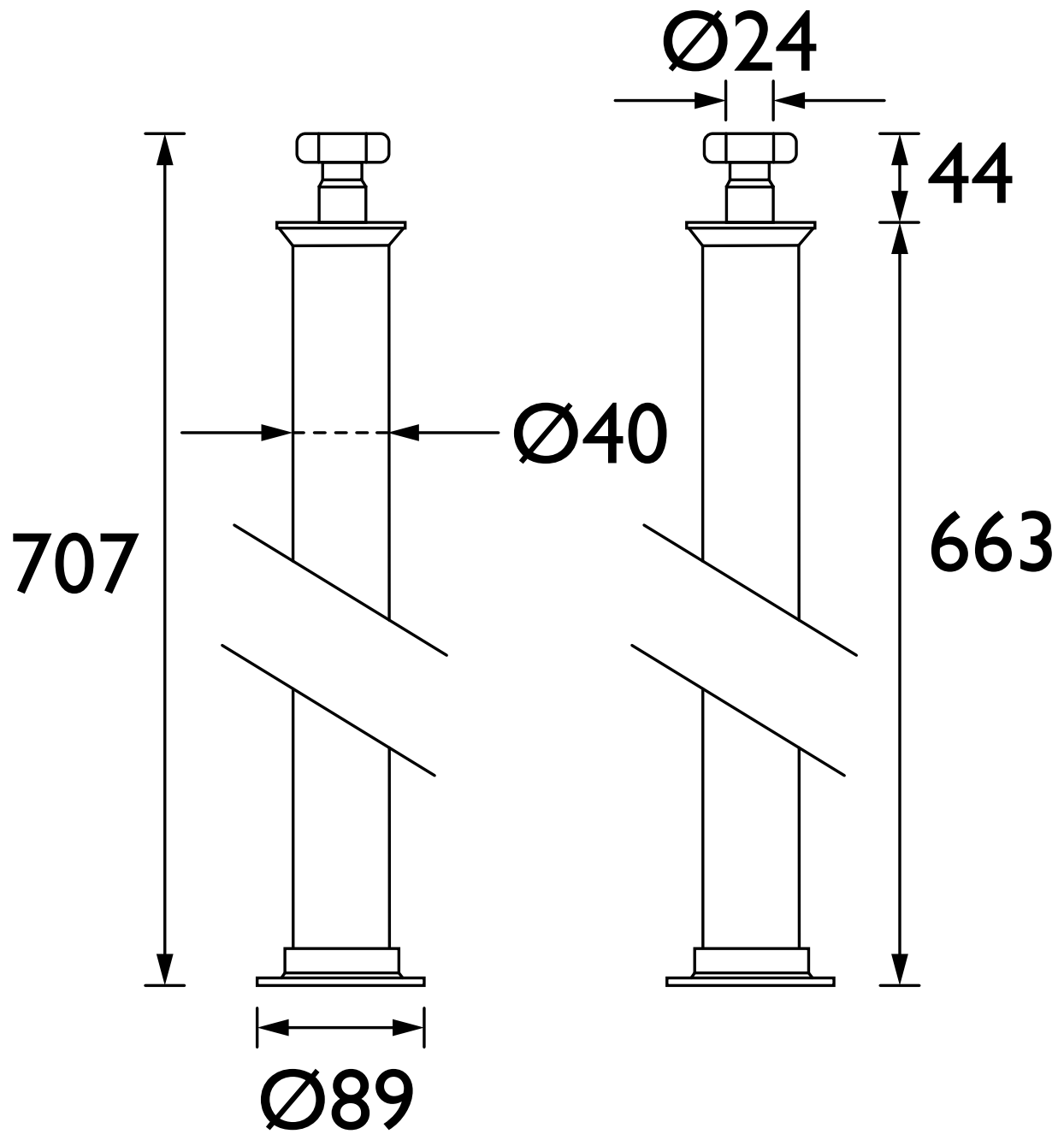

# PACK CONTENTS & INSTALLATION DIAGRAM

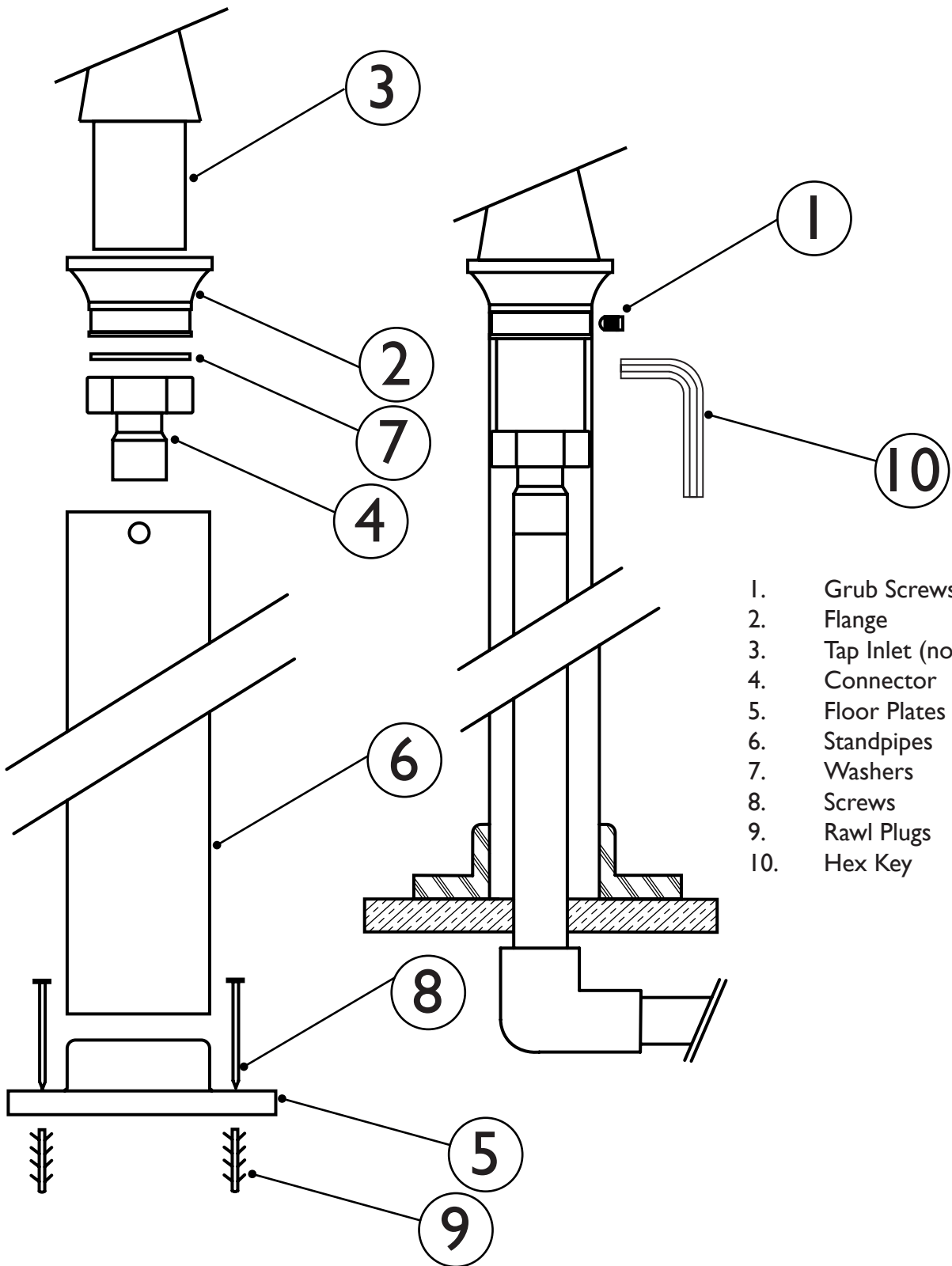

- 1. Grub Screws x4
- 2. Flange x2
- 3. Tap Inlet (not supplied)
- 4. Connector x2
- 5. Floor Plates x2
- 6. Standpipes x2
- 7. Washers x2
- 8. Screws x6
- 9. Rawl Plugs x6
- 10. Hex Key x1

---

# INSTALLATION OF STANDPIPES

---



Standpipes are designed to support taps or mixers near a freestanding bath and conceal the pipework which feeds up from under the floor to the taps.

**NOTE!**

Installation instructions are only a guide. The order in which the installation is carried out may be altered to suit on site conditions.

1. Identify all components and check for completeness, particularly before arranging fitting. Cover your taps to protect them from damage during installation.
2. Loosen the grub screws (1) on the standpipes (6), remove the flanges (2) and screw them, large diameter uppermost, onto the tails of the taps or mixer (3), (not supplied). We recommend using a suitable liquid sealant (not supplied) to ensure the tap inlet creates a seal.
3. Decide on the positioning of the taps against the bath, making sure the spout reaches.
4. Locate the pipe inlets under the floorboards and place the floor plates (5) in the desired position. Mark out the screw holes, drill and using the rawl plugs if necessary, screw the plates (5) to the floor.
5. The connector (4) can be brazed onto 22mm pipe work (not supplied) to create the vertical feed through the shroud to the taps or mixer. Use a suitable length to allow sufficient movement to aid assembly and to ease further connections below the floor.
6. Slide the standpipes (6) over the vertical pipes ensuring sufficient movement to allow connector (4) to reach the taps or mixer tails. Use the washer (7) to create a seal between the flanges (2) and the standpipes (6).
7. Connect the water feed/supply to the vertical pipes (inside the shroud) under the floorboards using elbows (not supplied). Turn the taps on and check all connections for leaks.
8. Screw the standpipes to the floor plates (5). Then secure the taps or mixer in position by positioning the shrouds (2) into the top of the standpipes (6) and tightening the grub screws (1).

---

## CARING FOR YOUR PRODUCT

---



Heritage products are made from premium materials, with hand polished, PVD, EPD or electroplated finishes.

Your product should be regularly cleaned with warm water, a mild pH-neutral liquid soap, and polished with a soft cloth. Any residues from soap, toiletries etc. should be rinsed off straight after use.

Household bleaches and cleaners contain harsh chemicals and may damage the surface finish. Avoid using abrasive cloths, scouring pads, scrub sponges, steel wool or anything similar.

---

## GUARANTEE

---

The confidence we have in the quality of our products and services enables us to offer a free peace-of-mind product guarantee from 2 years up to a lifetime guarantee against any manufacturing faults, with proof of purchase.

In addition, our attentive customer service team are available to help solve any problems which may arise quickly and effectively so you can enjoy your bathroom.

To see the specific guarantee for this product, scan the QR Code or visit the following URL:

<https://www.heritagebathrooms.com/service-centre/guarantee>

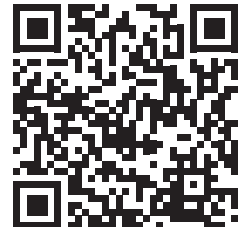

---

## NEED HELP?

---

If your product does not function correctly when you first use it, contact your plumber and make sure that it has been installed and commissioned in line with this Installation and User Guide supplied with the product. If this doesn't solve the problem, then please visit <https://www.heritagebathrooms.com/service-centre/help-and-advice> for some helpful hints and tips; or contact Heritage Customer Service on 0330 026 8503 where our expert team of advisors will be able to offer you, or your plumber, help and advice.

# HERITAGE<sup>®</sup>

## BATHROOMS

We love to see how Heritage products are used so please keep in touch and share pictures of your new bathroom with us.



@heritagebathrooms

**If you have any queries, our dedicated customer service teams and products experts are available to help.**

**Email us [enquire@heritagebathrooms.com](mailto:enquire@heritagebathrooms.com) Call us 0330 026 8503 Website [www.heritagebathrooms.com](http://www.heritagebathrooms.com)**

UK: Heritage Bathrooms, Pooley Hall Drive, Birch Coppice Business Park, Dordon, Tamworth B78 1SG

EU: Masco Europe S.à.r.l., 14 Rue Strachen, 6933 Mensdorf, Luxembourg.